



OVERVIEW

Foodservice equipment manufacturers design equipment to meet the needs of many different types of foodservice systems. Manufacturers vary on features that are standard to their equipment design. While some features are standard for one manufacturer, the same feature may be considered an accessory or an option at extra cost for another manufacturer. It is important for you to refer to the manufacturer's specifications for the detailed information you will need when making equipment purchasing decisions.

Chapter 5 discusses the foodservice equipment by functional areas in a conventional foodservice operation. A functional area is a location within the foodservice system where a specific task or group of like tasks occur. The functional areas discussed in the *Guide* are:

- Receiving
- Dry Storage and Chemical Storage
- Cold Food Production
- Hot Food Production
- Warewashing

Regardless of the production demands of the foodservice system, grouping tasks by functional areas provides benefits to the foodservice operation. Some of the benefits include:

- multi-use of individual pieces of foodservice equipment
- efficient flow of food from receiving through preparation to service
- storage of small equipment and utensils within ready access
- prevention of back tracking which is inefficient
- support of food safety principles
- support of inservice education for the foodservice assistant

Additional resources for you to use are the Equipment Purchase Decision Forms found in Appendix, p. A.11. The questions and forms have been reprinted from *Guidelines for Equipment to Prepare Healthy Meals* (Nettles & Carr, 1996). The forms will help you organize your thoughts when purchasing foodservice equipment for your CNP.



RECEIVING

Receiving is a functional area and the first step in the flow of food through a foodservice system. It is the important interface between the distributor and the CNP. For that reason, the receiving area functions as a control point for most food and a critical control point (CCP) for processed and ready-to-eat food.

Regardless of the size of the foodservice system, the activities associated with receiving are the same. The purpose of these activities is to ensure food quality and food safety. For training assistance in this area refer to the 1998 program *All-Star Receiving for Child Nutrition* (Hogue and Post, 1998).

The activities of the receiving function include:

- Visually inspect all items and look for signs of contamination or container damage.
- Check expiration and pack dates.
- Count boxes invoiced but not delivered; note shortages.
- Check the product number against the purchase order or receiving ticket. Only accept approved brands.
- Check substitutions for approved brands.
- Check temperatures and record on chart.
- Remove any loose staples or fasteners.
- Reject unacceptable goods and note on invoice.
- Sign the invoice and retain a copy.

Each CNP must locate an area within the foodservice system to accomplish these tasks. The objective of good receiving practices is to certify that all food moved into production is an approved brand. In addition, receiving is the opportunity in the flow of food to determine that products are in good condition, appropriate temperature, and delivered as ordered.

Suggested equipment for the receiving area in a conventional kitchen includes:

- 2 wheeled hand truck and/or
- 4 wheeled platform hand truck
- utility carts
- table/desk for paperwork
- scales
- thermometers
- fly fan

Equipment by Functional Areas



DRY STORAGE/CHEMICAL STORAGE

After receiving food and supplies the foodservice assistant moves the goods to dry, refrigerator, and freezer storage. This is the second functional area. Most CNPs should turn their dry inventory regularly for quality and cost control. Dry storage and chemical storage, although similar in function, must have all contents stored separately. Food must never be mixed in a storage area with chemicals or cleaners.

The dry storage area should be clean, dry, well ventilated, and temperature controlled. The recommended dry storage temperature is between 50° F - 70° F. Shelving selection will impact air circulation, pest prevention, and first-in first out (FIFO). There are a variety of shelving options.

Style and finish of shelving should be consistent with storage application and budget.

Style examples include:

- open wire
- louvered
- embossed or raised steel
- solid
- vented, steel reinforced plastic
- polymer composite

Finish examples include:

- galvanized - solid, embossed or louvered
- zinc
- chrome
- zinc plating and organic coating

NSF requires shelving systems to be non-rusting, and approved for direct contact with food.

For example:

- polymer - composite (ideal refrigerator, pot and pan, meat, and fish storage)
- polymer - reinforced stainless steel

Boxes and cases should be discarded so only clean and marked cans, tubs, and bags are stored on shelves in the dry storage area. Organize these shelves with like items together to facilitate inventory and promote food issues to the production area.



Shelving Systems

Types of shelving systems:

- stationary - put in place and remain for a period of time, lacks versatility
- mobile - similar to stationary but has casters
- track - also known as high density or active aisle shelving, derivative of mobile system with mount or guided on a track (floor or ceiling)
- wall mounted - adjustable cantilever shelving - adjust to various heights, ease of cleaning

The CNP planning for a shelving system should include:

- analyze typical goods stored
- size of can(s) (or other type container)
- space allowed for aisle (walk both sides, carts)
- specialty shelving like bag-in-the box
- delivery schedule

Suggested equipment for the dry storage area in a conventional kitchen includes:

- shelving system
- dunnage racks
- can storage rack (optional)
- utility carts

Food and chemicals are stored separately to prevent any possibility of chemical poisoning. Your local chemical supplier can make recommendations for chemical storage organization.

Suggested equipment for the chemical storage area in a conventional kitchen includes:

- shelving system
- janitor sink
- washer/dryer (optional)

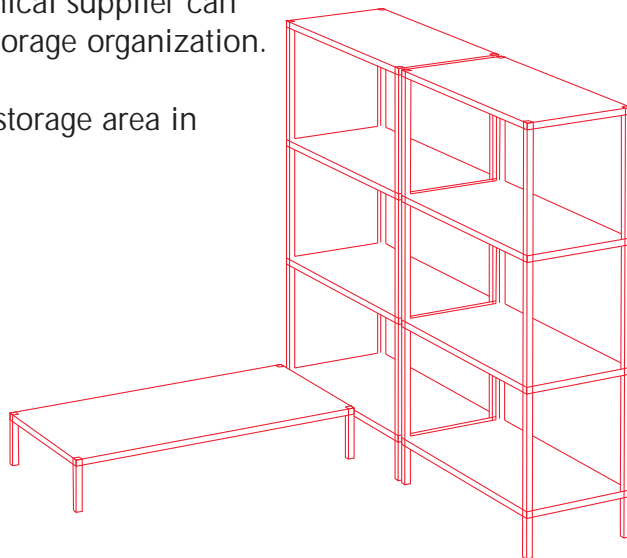

COLD FOOD PRODUCTION

Cold food production is a functional area that requires refrigeration, equipment, water, and a work area. A variety of activities take place in this area from washing produce for preparation to slicing, chopping, mixing, and plating.

The CNP will want to organize the cold food production area to:

- produce the menu in a timely and efficient manner
- ensure food safety which includes thoroughly washing produce and adequate refrigeration of ingredients and completed recipes
- provide a work flow that is efficient and safe for employees

The equipment described for cold food production in a conventional kitchen includes:

- refrigerator/freezer
- blast chiller
- ice machine
- mixer
- slicer
- cutter/mixer

Employee competence to operate a slicer, cutter/mixer, or other equipment should be certified before the equipment is used.



Cooling Units

Most refrigeration and freezer systems have a compressor, a condenser (air or water cooled), an evaporator, and a fluid called refrigerant. This system moves heat out of food via moving air.

Refrigerators

There are a wide variety of refrigerator units found in CNPs. They include:

- walk-in
- reach-in
- pass-through
- under the counter
- roll-in
- soft serve
- ice cream cabinet
- display refrigerator

The purpose of the refrigerator is:

- keep food cold
- reduce the rate of deterioration by diminishing enzyme activity
- control the growth of microorganisms that potentially can cause foodborne illness
- maintain food quality

Walk-in Refrigerator/Freezer

The walk-in refrigerator or freezer is designed for bulk storage. Virtually any size is available. Most walk-ins today are pre-engineered (prefabricated) panelized construction which makes them flexible within the space available.

Constructed of a series of 4" (1.0 cm) thick manufactured and modular panels, individual panels are attached with a variety of latches, camlocks, or bolts to form outer walls, ceilings, and in some cases the floor. There is a variety of heights, lengths, and widths available.

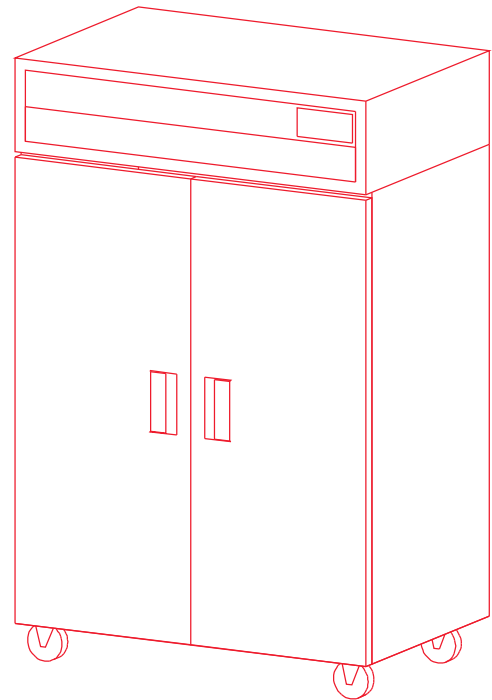

These are specified either self-contained (side or top mounted), quick-connect, or remote refrigerator system. Sufficient air space must be available around cooling units to prevent build up of excess heat.

Primary factors in refrigerator/freezer selections include:

- total amount of storage
- amount of space available
- frequency of product delivery
- shelving needed
- CNP menu

Other considerations in equipment selection include:

- condition of floor
- condition of ceiling (proper ventilation of unit's condenser)
- access to work area traffic flow
- requirement for special equipment
- power available
- local permits or codes
- location of door/door swing

Rule of thumb for sizing is a cubic foot (15.24 cubic cm) of usable storage space per meal served.

Reach-in Refrigerator/Freezer (near production area):

- versatile
- reasonable cost
- storage efficiency

One, two, three compartment - many options available depending on:

- budget
- capacity
- general storage, special products
- should eliminate interior shelves to adapt refrigerator for roll-in carts

Determine capacity and size by:

- approximate number of meals
- receiving schedule
- kitchen space available

Reach-in capacity refers to available interior space.



Keep in mind:

- evaporators
- lights
- tray slides

Typical interior capacity:

- single compartment
21.5 cubic foot/.6 cubic inch
- double compartment
46.5 cubic foot/1.3 cubic inch
- triple compartment
70.0 cubic foot/2.0 cubic inch

Standard features:

- dial thermometer
- heavy duty hinges
- self closing door with safety stop
- flush mounted automatic interior light
- door opening for 12" X 20" and 18" X 26" pans
- heavy duty cylinder locks
- adjustable legs
- NSF approved shelving

The NSF and FDA are recommending lower holding temperatures. Check local health codes for cold food holding temperatures.

Table 5.1 Refrigerator/Freezer Temperatures

Storage	Temperature Ranges
Dairy	34° - 40° F
Frozen	-10° to 0° F
Ice cream	-10° F
Meat / Poultry	34° F
Fruits	38° F
Vegetables	38° - 40° F

Blast Chiller

The blast chiller is designed to rapidly cool almost any kind of food. Once thought to be only needed in a cook-chill system, the blast chiller has taken on a new place in food production.

An essential component of a Hazard Analysis Critical Control Point (HACCP) system is time-temperature holding of food. This includes proper cooling. The data verifies that the primary cause of foodborne illness in the United States is improper cooling of hot food as bacteria thrive in the temperature danger zone (40° F - 140° F) (cold food holding in some areas is a minimum of 41° F).

There are recommended procedures to cool food. However, if use of one of them is not routinely used, a blast chiller is recommended.

Cooling hot food in a foodservice walk-in or reach-in refrigerator can pose a serious risk of foodborne illness. These units are designed to store food that is already cold. They were not designed to chill hot food. Refrigerators don't create enough air flow to pull hot food through the danger zone to below 40° F in the recommended amount of time.

The capacity of the blast chiller (in pounds) per load equals the number of persons the chiller can serve for three meals per day.

Selecting a blast chiller:

- product brought to below 40° F in 90-120 minutes or less
- footprint (overall size, dimension and shape)
- installation and maintenance requirement
- available training
- easy to understand and use operating manuals
- consultation and technical support
- quality construction materials
- parts availability
- time/temperature reporting
- ease of cleaning and maintenance



Ice Machine

Commercial ice machines are actually small manufacturing plants. They utilize water and electricity to make ice. Ice is considered a food and must be handled like a food. A total system has three major components:

- ice production - flakes or cubes
- ice storage - varying capacities 400 - 500 pounds, refill automatically or manually, stand or floor models with insulated equipment and a drain; normally constructed of either plastic, aluminum, galvanized steel, stainless steel, or combination of materials
- counter dispensing - moves the ice from storage bin to glass (gravity feed common)

Ice machines are rated according to the amount of ice the machine produces within 24 hour period. Consider, storage bin plus the amount the ice machine can produce during the peak period = total ice available.

A storage bin must be selected that is slightly larger than the machine's rated production capacity (risk ice melt in bottom). Carefully select a bin to meet production and service needs.

Three types of condensers:

- air cooled - generally cost less and easy to install, but tends to heat environment around them
- water cooled - uses water to remove heat, no fan, quiet to run
- remote air cooled - heat dispelled through a vent, usually located on the roof, more costly to install but can reduce monthly bills

Other notes:

- a water filter should be installed regardless of the water conditions
- ice machines usually run 16-18 hours daily
- ice machines require 20 lbs. per square inch of water pressure
- optimum water temperature is 50° F - 70° F

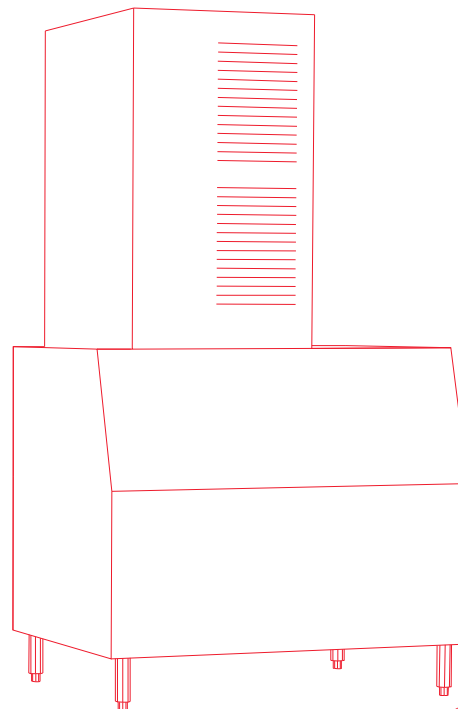

Mixer

The mixer is considered a valuable and versatile piece of equipment because of the variety of attachments. There are numerous manufacturers and models of mixers on the market. Planetary action mixing provides thorough blending and mixing action by repeatedly turning the mixed product into the center of the bowl. Mixers range from table top to 140 quart models geared to high volume institutional use.

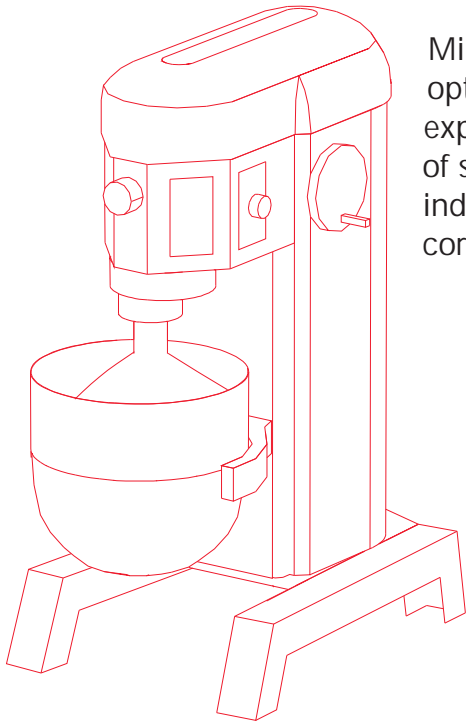

Mixers have a wide application with standard and optional attachments to meet the needs of changing and expanding food service menus. Mixers come in a variety of sizes/capacities, ranging from 5 quart to 140 quart, indicating the bowl size. The applications determine the correct size needed.

Table 5.2 Mixer Information

Mixer Capacity	Application	Space Design
5 quart	Specialty Mixer	Counter
12 quart	Small-General Purpose Mixer	Counter
20 quart	General Purpose Mixer	Counter or Floor
30 quart	Light/Heavy Duty Mixer	Floor
40 quart	General Purpose Mixer	Floor
60 quart	Pizza Dough Mixer	Floor
80 quart	General Purpose Mixer	Floor
140 quart	Heavy Duty Mixer	Floor



Standard features:

- mixing bowl - bowl size depends on the size of mixer purchased: 5, 12, 20, 30, 40, 60, 80 quart
- 140 quart size, depending on model of mixer purchased, may be available
- agitators - flat beaters, dough arms, wire whips, pastry knife
- variable speed motor - usually in smaller quart capacity models, tend to bog-down with low rpm (heavy loads)
- lift mechanism raises bowl to agitator (larger models)
- housing column and base constructed of cast iron, cast aluminum, or welded steel
- surface finished with tough polyurethane, baked enamel, stainless steel or polished aluminum exterior skin
- bowl stabilized with use of hand-locking clamps attached at sides
- some have fixed bowl positions, others offer variable height selections
- power take-off hub for attaching other devices (grinders and slicers) located on front

Optional attachments and accessories available at extra cost:

- vegetable slicer - slices vegetables
- plate holder assembly - attaches to vegetable slicer to mount grater plates
- bowl splash cover - controls the splashing of wet and dry ingredients
- bowl extension attachment - increases height of bowl to decrease whipped ingredients from being thrown from the bowl
- bowl truck - used to move floor models as well as moving larger bowls into place
- bowl adapter - to be used when larger mixers are used with smaller capacity bowls
- bowl scraper - used to reduce labor costs of manual bowl scraping
- food chopper or grinder - used to grind boneless meats, vegetables and nuts
- food dicer - produces french fries, vegetable sticks as well as diced vegetables
- soup strainer/colander - replaces the mixer bowl, agitator is replaced by a roller or brush assembly, roller is used for slicing potatoes or vegetables, brush is used to remove seeds from fruit for jams or jellies
- stop and start controls
- programmable controls



Slicer

There are numerous manufacturers of slicers on the market. Most are designed to slice high volume amounts of meat and cheese quickly and efficiently. Slicers vary in size, depending on the need of the CNP. Smaller manually operated models with 10" knives are ideal where occasional slicing is done. Larger models with 12" knives are best when large volume slicing is done. Most models are operated in either a manual or an automatic setting. Blade sharpeners are built in, some are easier to use than others depending on the brand and model. Most are designed to dismantle for easy cleaning and sanitation.

The slicer (manual or automatic) may be used for:

- slicing hot or cold meat in uniform thickness
- slicing cheese in uniform thickness
- slicing vegetables with optional accessories

Standard features:

- gear driven or belt driven
- blade sharpeners, some removable, other not, push button, top mounted
- lift off top covers, for ease of cleaning/sanitizing
- permanent ring guard
- knives are either stainless steel, chrome plated, or carbon plated steel
- adjustable thickness regulator

Options and accessories available at extra cost:

- optional carriage fences to slice tomatoes
- food chutes to slice elongated vegetables
- food receiving tray

Advantages:

- labor saving
- maximum product yield - less waste
- ease of operation
- safe to operate - less incidence of work related knife accidents

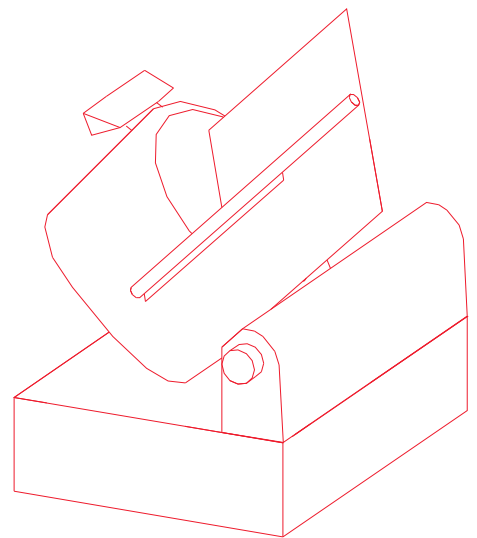

Cutter/Mixer

Also known as vertical cutter mixer (VCM), this equipment:

- prepares food quickly
- versatile piece of equipment; based on blender concept
- consists of conical mixing bowl with motor mounted at the bottom.
- removable sleeve with cutting blades mounted on the motor shaft which projects from the bottom of the bowl

Model information:

- 10, 15, 20 quart - counter top
- 25, 40, 60, 80, 130 quart - floor mounted

Standard features:

- clamp down lids, transparent material or metal (slide back viewing portal)
- operated - hand or motor
- rotating lever on top - turns bottle
- main drive motor - usually 2 speeds
- 1 hp to 25 hp units
- stainless steel bowl
- cannot operate unless bowl and lid are in place
- pulse control
- power indicator lights

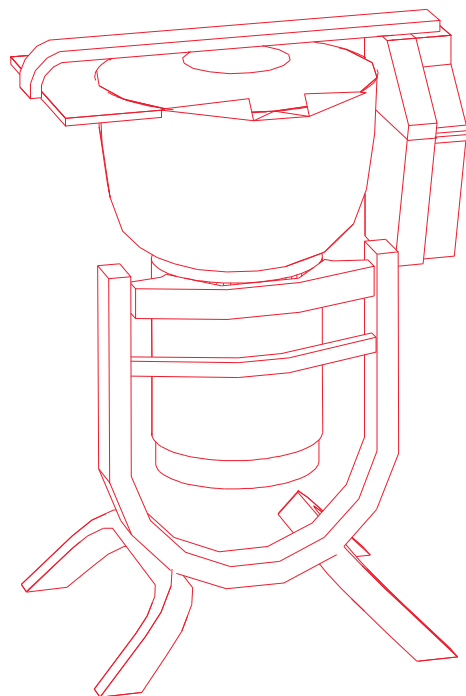

HOT FOOD PRODUCTION

Hot food production is a key area in the conventional foodservice system. Activities that take place within the cooking area are grouped according to the type of treatment required. For hot food that includes:

- seasoning
- mixing
- shaping
- breading
- panning
- cooking

The selection of type of equipment is affected by factors like:

- food to be processed (menu)
- type needed (bake, fry, steam)
- labor availability and skill
- serving schedule

Heat is applied to food to increase digestibility and customer appeal. Nutrient retention and food safety are always considerations. Heat is transferred to/from a product in four ways:

- conduction - molecule to molecule, example: pot or range top, oven, steam
- convection - heat transmitted through liquid or gas to food, example: convection oven
- radiation - radiant waves
- induction - raise heat because pan is subjected to alternating electromagnetic field; with this process the operator must use stainless steel cookware.

In the hot food production area, attention to internal cooking temperature, time-temperature monitoring, and minimum time in the danger zone are all important. Your CNP will want to post internal temperature requirements for all meat items in the production area. For more information on equipment selection refer to *Guidelines for Equipment to Prepare Healthy Meals* (Nettles & Carr, 1996).



The following equipment described for hot food production in a conventional kitchen includes:

- tilting braising pan
- steam jacketed kettle
- direct steam kettle
- convection steamer
- pressure/pressureless steamers
- pressure steamers
- high pressure steamers
- combination oven/steamer
- convection ovens
- fryers
- range

Like other pieces of foodservice equipment, the selection of each piece should be based on the guiding principles described in detail in Chapter 1.



Tilting Braising Pan

The tilting braising pan is also known as tilt skillet or tilting frypan. It is a one piece stainless steel pan with vertical side walls, a front pouring lip, and hinged stainless steel cover; it is also considered a griddle with high sides and a cover.

The tilting braising pan has a variety of applications like: braise, grill, pan fry, saute, steam, and boil

Examples:

- brown or braise stew meats, ground beef
- shallow pan fry chicken, fish
- saute vegetables, stir fry
- cook soups, stews, sauces
- back-up grills, steamers, kettles
- steam vegetables with optional steamer pan insert rack

Options and accessories available at extra cost:

- steamer pan insert assembly
- receiving pan support
- pour lip strainer
- flow diverter
- vented lid
- single or double pan fry faucet with swing spout
- tangent draw-off valve
- solid state temperature control
- electronic ignition (gas models)
- spray hose assembly
- casters
- special electrical options
- gallon markings
- special stands (counter top models)

Configuration:
counter top, tubular
leg base, open or
closed base, wall
mount

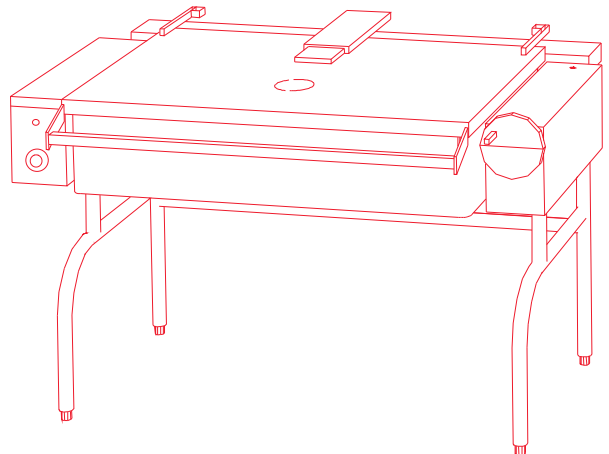

Standard features:

- stainless steel welded one piece braising pan
- coved interior corners
- manual or motor driven power tilt
- formed pouring lip
- hinged stainless steel lid (floor models)
- thermostatic temperature control
- adjustable feet
- power “on-off” switch
- operating temperature range of 100° F to 450° F
- receiving pan support
- indicator light for power “on”

Advantages of the braising pan:

- versatile
- reduced preparation and cooking times
- labor saving - easy clean-up; reduces use of extra pots and pans

Installation tips:

- Install floor sink or grate in line with the braising pan pour path. The pour path is detailed on the manufacturer’s specification sheet.

Table 5.3 Tilting Braising Pan Information

Model/Type	Sizes and capacities
Counter top models - electric only	10, 12 and 15 gallons
Floor models - gas or electric	23, 30 and 40 gallons



Steam Jacketed Kettle

A steam jacketed kettle is cylindrical in shape with a rounded bottom. A second larger cylinder is placed around the outside of the main cylinder creating a space between the two. This space is sealed so that steam may be injected. As steam enters this space it releases its energy (heat) by condensing onto the inner kettle's outer wall. This transfers heat to the food being cooked. Consider a double boiler used in a home kitchen. A steam jacketed kettle is the same basic concept.

There are two designs in kettles - a fully jacketed and a two-thirds jacketed kettle. Within the basic design of the fully jacketed kettle, there are two varying designs in the interior construction. One design is described as a hemispherical bottom interior. The other is described as a dish type slopped interior.

Kettles are available in direct steam or self-contained electric or gas that are tilting or stationary.

All stationary models are supplied with a food draw-off system. There are two designs and varying sizes available on the draw-off valve, the tapered plug type, and a screw type gate valve (compression valve). Both are available in 1½", 2", and 3" sizes.

The steam jacketed kettle is used for boiling, stewing, simmering, braising, holding, and rethermalizing (reheating).

Examples:

- soups, stews, sauces, gravies
- pasta, rice
- puddings, pie fillings
- vegetables
- cereals
- meat roasts, corned beef, poultry
- shrimp, lobster
- tea

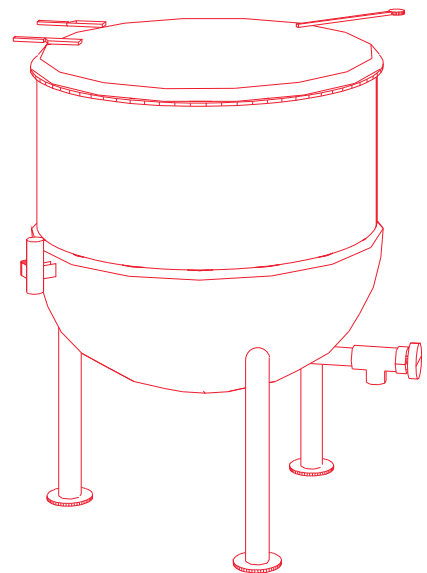

Some CNPs use the kettle to quickly chill foods (ice bath) or to mix cold salads. When purchasing a kettle consider both gas and electric options.

Manufacturers vary in type, models, and capacities. Refer to manufacturer's specification sheet for detailed information.

Standard features:

- stainless steel interior and exterior, type 304 stainless steel kettle liner
- low water safety control system
- jacket pressure gauges
- thermostat temperature controls
- factory charged with chemically pure water, rust inhibitors, and antifreeze
- pressure relief valve
- stationary floor models include cover and 2" draw-off valve and perforated stainless steel strainer
- adjustable feet
- pouring lip for tilting models
- 25-50 psi steam jacket rating
- design certified by ASME, AGA, UL, NSF

Options and accessories at extra cost:

- type 316 stainless steel liner for high acid products
- 3" tangent draw-off valve
- cooking basket assembly
- water fill faucets
- swing funnel for drain
- flow diverter (tilting kettle)
- gallon markings
- condensate ring on covers
- kettle brush kit
- electronic ignition (gas models)
- special electrical options
- lift off or hinged lid



Table 5.4 Kettle Information

Type/ Model		Size/Capacity
Table top	tilting, electric gas	6 - 15 gallon 20 - 40 quart
Tri-leg	stationary, electric tilting, electric	20 - 80 gallon 20 - 100 gallon
Pedestal base	stationary, electric tilting, electric	20 - 100 gallon 20 - 80 gallon
Tri-leg	stationary, gas	25 - 150 gallon
Tri-leg	tilting, gas	20 - 80 gallon



Direct Steam Kettle

Direct steam kettles operate with steam provided by a remote steam source. Consult with your manufacturer or sales representative to calculate steam flow rate requirements for the optimal performance of the kettle.

Standard features:

- stainless steel interior and exterior, type 304 stainless steel kettle liner
- steam control kit: steam control valve, steam trap, condensate strainer, check valve
- 25-50 psi steam jacket rating
- stationary floor models include cover 2" draw-off valve and perforated stainless steel strainer
- pressure relief valve
- pouring lip for tilting models
- adjustable feet
- design certified by ASME, NSF, UL

Options and accessories at extra cost:

- type 316 stainless steel liner for high acid products
- cooking basket assembly
- water fill faucets
- swing funnel for drain
- flow diverter (tilting model)
- gallon markings
- condensate ring on covers
- increased psi option
- pressure reducing valve for regulating incoming steam pressure
- hinged or lift off cover
- kettle brush kit

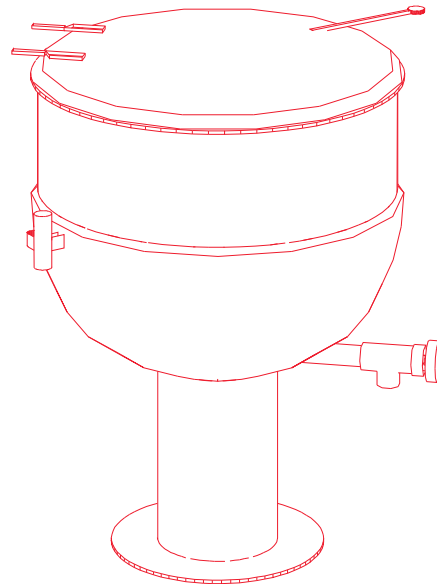

An optional piece of equipment is the mixer kettle. Agitator and scraper assemblies are available for most direct and self-contained electric, table top, and floor mounted kettles. This kettle, also referred to as cooker/mixer, features a mechanical mixing unit which can eliminate the manual stirring of ingredients. This saves labor time. The mixing of the agitators/scrapers reduces cooking times.

Advantages of mixer kettles:

- reduce cooking times by enhanced heat transfer to foods
- reduce cooling times when water cooling system installed (direct kettle)
- keep solid ingredients suspended in liquids which is necessary when pumping food from kettle

Wall-mounted kettles can be mounted and installed on in-wall support arms (wall carriers). This feature provides for optimum sanitation. This type of installation may be seen in conjunction with energy distribution systems.

Installation tips:

Make certain that the floor drain or grate is located in line with the kettle's pour path or draw-off valve. These details are provided on the manufacturer's specification sheet.

Provide a water source either mounted on the kettle as a swing spout faucet, fill faucet or some other shared source such as a water tower.



Table 5.5 Kettle Size Information

Model/type	Size/capacity
Table top	6 - 20 gallon
Tri-leg stationary	20 - 150 gallon
Tri-leg tilting	20 - 100 gallon
Pedestal base - stationary	20 - 150 gallon
Pedestal base - tilting	20 - 80 gallon
Cabinet mounted - stationary	20 - 60 gallon
Cabinet mounted - tilting	25 - 60 gallon

Advantages:

Most advantages related to cooking with kettles are based around the efficiency of heat transfer by steam to the inner wall of the kettle. Other advantages are based on the design and construction of the kettles. For example:

- short cooking cycle
- vegetables cook with minimum loss of nutrients, color, and flavor while maintaining firm texture
- cleaning is sanitary and simplified
- smooth, rounded surfaces are quickly cleaned
- uniformity of cooking
- foods protected from burning; no hot spots, no scorching
- optimum use of floor space
- using vertical space makes a small floor area do a large production job



Convection Steamer

Each manufacturer varies in how steam is supplied to the cooking compartments and what controls are used to perform this function. Pressureless steamers are available with self-generating gas or electric steam coil generators and direct steam models. The steam is supplied from an outside source. Direct steam units require a clean, potable steam supply.

Each compartment will equate capacity by the number of 12" X 20" X 2" deep pans it will hold. Perforated pans are preferred when possible for more consistent cooking but solid pans are acceptable. Capacities vary among equipment manufacturers.

These steamers require a water supply which fills the steam generator/boiler and supplies the cold water condensate system. Open air gap floor drains are also required within a specific distance from the steamer.

Application:

Steam cooking, defrosting, and rethermalizing

Examples:

- vegetables (fresh and frozen)
- rice
- pasta
- eggs
- poultry
- seafood
- meats
- prepared foods
- frozen entrees
- hot dogs
- potatoes

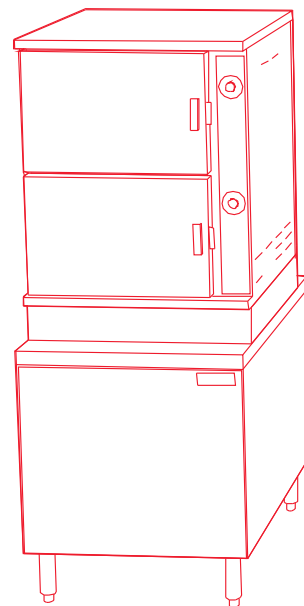

Standard features:

- convection steam flow, pressureless, free venting cooking compartments
- capacity in 12" x 20" X 2" pans
- compartment controls are mechanical or solid state and include a timer, indicator lights, and buzzer
- steam generator/boiler controls include "on-off" switch, indicator light, automatic water fill, automatic water level controls, safety controls, automatic steam generator/boiler blow down
- stainless steel exterior and enclosed modular cabinet base
- insulated stainless steel interior cooking compartment with removable pan slide racks
- cold water condensate system
- cooking compartment drain
- separate electrical connection for controls
- electronic ignition for gas models
- 6" stainless steel legs
- visible steam generator pressure gauge
- steam generator/boiler delimiting assembly

Options and accessories available at extra cost:

- alternate cooking compartment controls
- assembly of valves and tubing to connect an auxiliary kettle
- alternate hinging of cooking compartment door
- special state boiler code requirements
- adjustable flanged feet
- special electrical requirements
- 6 or 10 gallon tilting kettle mounted to expanded base
- water faucet/spray hose supply

Table 5.6 Convection Steamer Information

Model/Type	Size/capacity in 12"X 20"X 2" pans
Pressure generator - electric, gas, steam coil, direct steam	6, 10, 16
Atmospheric generator - electric, gas	6, 7, 10, 12, 24
Pressure generator-electric, gas steam coil, direct steam	10, 16



Advantages:

- enhanced food quality and retained nutrients
- form and texture retained
- color retained
- shrinkage minimized
- nutrient retention
- energy efficient
- less BTU's used to cook the same quantity of food
- labor efficient
- less time required to prepare food due to better heat transfer
- less hands-on required in production and clean-up, no stirring needed, same pans used in cooking may be used in serving
- optimize floor space
- more food cooked within the floor space required by a range

Additional advantages when compared to pressure steamers:

- flexibility of loads
- cooking cycle may be interrupted to adjust loads by opening the door at any time
- no flavor transfer, different foods may be cooked at the same time in the same compartment
- color retention of foods
- pressureless steam temperature is 212° F. (steam temperature under 5# of pressure will be 227° F)
- form and texture of foods
- no cellular breakdown of foods due to pressureless atmosphere
- broadened application
- defrost capability allows cooking of either frozen or fresh products

Installation tips:

- recommend a water treatment system be installed to enhance preventive maintenance
- stay within the distance for drains required by the manufacturer



Pressure/Pressureless Steamer

These steamers offer the flexibility to operate in a pressure steam mode or a pressureless steam mode. There are two types of pressure/pressureless steamers manufactured. One type offers two or three cooking compartments where the top compartment is converted from a pressure to a pressureless mode and the bottom cooking compartments always operate in a pressure mode. The pressure mode for this type operates at 5 or 6 psi depending on the manufacturer. The steam temperature is approximately 228° F (109° C). The other type offers two cooking compartments where both may be converted from a 10 psi pressure mode to a pressureless mode. The steam temperature is 240° F (116° C).

These steamers are generally mounted on a 36" wide cabinetized base. Each cooking compartment may accommodate six to eight 12" x 20" x 2" pans or up to four 18" x 26" sheet pans. A smaller model is also available mounted on a 24" wide cabinetized base. This model accommodates three 12" x 10" x 2" pans per cooking compartment.

Steamers are available in self-generating electric and gas steam generator models. They are also available in steam coil generators and direct steam models whereby the steam is applied from an outside source. Direct steam units require a clean, potable steam supply.

Self-generating pressure steamers may be specified to supply steam to an auxiliary piece of equipment such as a kettle.

Application:

Steam cooking, defrosting, and rethermalizing

Examples:

- vegetables (fresh and frozen)
- rice
- pasta
- eggs
- poultry
- seafood
- meats
- prepared foods
- frozen entrees
- hot dogs
- potatoes

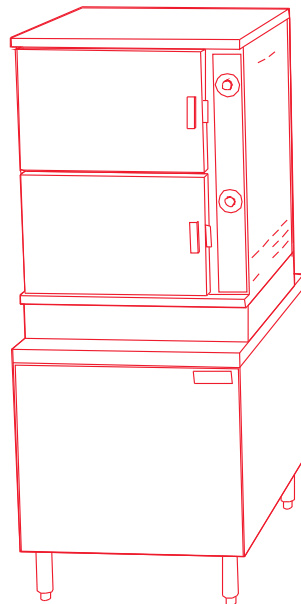

Standard features:

- cooking compartment convertible from pressure mode to pressureless mode (see description for types)
- convection steam flow, pressureless, free venting cooking compartments
- capacity in 12" x 20" x 2" pans
- compartment controls are mechanical or solid state and include a timer, indicator lights and buzzer
- steam generator/boiler controls include "on-off" switch, indicator light, automatic water fill, automatic water level controls, safety controls, automatic steam generator/boiler blow down
- stainless steel exterior and enclosed modular cabinet base
- insulated stainless steel interior cooking compartment with covered corners and removable pan slide racks
- cold water condensate system
- cooking compartment drain
- separate electrical connection for controls
- electronic ignition for gas models
- 6" stainless steel legs
- visible steam generator pressure gauge
- steam generator/boiler delimiting assembly

Table 5.7 Pressure/Pressureless Steamer Information

Model/Type	Size/capacity
Electric steam generator 42/48 KW	2, 3 compartments
Gas steam generator 250,000/300,000 BTU	2, 3 compartments
Steam coil generator	2, 3 compartments
Direct steam	2, 3 compartments

Options and accessories at extra cost:

- alternate cooking compartment controls
- assembly of valves and tubing to connect an auxiliary kettle
- alternate hinging of cooking compartment door
- California or Washington state boiler code requirements
- adjustable flanged feet
- special electrical requirements
- water faucet/spray hose supply



Advantages:

- allows the flexibility of cooking in a pressure steam mode or pressureless steam mode
- provides advantages as described for the pressure steamers
- provides advantages as described for the pressureless steamers

Installation tips:

- recommend a water treatment system be installed to enhance preventive maintenance
- stay within the distance for drains required by the manufacturer
- steamers require a cold water supply which fills the steam generator and supplies the cold water condenser
- open air gap floor drains are also required within a specific distance from the steamer



Pressure Steamer (Low and High)

There are two categories of pressure steamers manufactured. One category is known as low pressure steamers and the second as high pressure steamers. Each will be described separately.

Low pressure steamers are usually mounted on a 36" wide cabinet base and have two to three cooking compartments. Steamers are available in self-generating electric and gas steam generator models. They are also available in steam coil generators and direct steam models whereby the steam is supplied from an outside source. Direct steam units require a clean, potable steam supply. Direct steam units are also available with four cooking compartments.

Each compartment can accommodate six to eight 12" x 20" x 2" deep pans. Perforated pans are preferred. Sheet pans, 18" x 26" may also be used. Pan capacities vary among manufacturers.

Pressure steamers are recommended for cooking like foods per batch or compartment load, as flavors may transfer.

Self-generating pressure steamers may be specified to supply steam to an auxiliary piece of equipment such as a kettle.

Application of both low and high pressure steamers.

Examples:

- vegetables (preferably non-frozen)
- potatoes
- rice
- pasta
- eggs
- poultry
- corned beef
- stew meats
- pot roasts
- hams



Standard features of low pressure steamers:

- 5 psi operating pressure in cooking compartments
- capacity in 12" x 20" x 2" pans or 18" x 26" sheet pans
- compartment controls include a timer, indicator light, and buzzer
- steam generator (boiler) controls include "on-off" switch, indicator light, automatic water fill, automatic water level controls, safety controls, automatic steam generator (boiler) blow down
- cooking compartment drain
- automatic exhaust for cooking compartment
- electronic ignition for gas models
- visible steam generator pressure gauge
- stainless steel exterior and enclosed modular cabinet base
- 6" stainless steel legs
- cold water connection
- load compensating timer

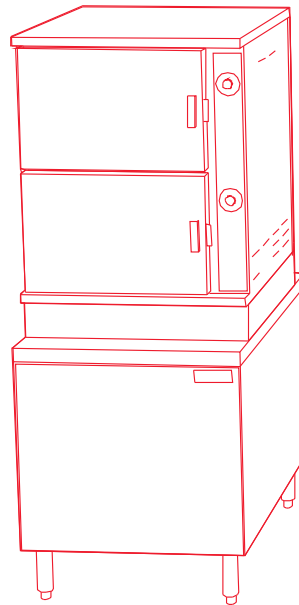

Table 5.8 Pressure Steamer Information

Model/Type	Size/capacity
Electric Steam Generator	2, 3 compartments
Gas steam generator	2, 3 compartments
Steam coil generator	2, 3 compartments
Direct steam	2, 3 compartments

Options and accessories at extra cost:

- assembly of valves and tubing to connect an auxiliary kettle
- water treatment system
- California or Washington state steam generator controls
- boiler delimiting assembly
- PRV - pressure regulating valve
- ball float trap (direct and steam coil models)
- manual sliding shelf
- KW increased on electric elements
- BTU increased on gas burners
- special electrical requirements
- adjustable flanged feet
- casters
- water faucet/spray hose supply
- stainless steel gas flue cover

Advantages:

Observed when compared to conventional range top cooking:

- enhanced food quality and retained nutrients
- form and texture retained
- color retained
- shrinkage minimized
- energy efficient
- less BTUs used to cook the same quality of food
- labor efficient
- less time required to prepare food due to better heat transfer
- less hands on required in production and clean-up
- no stirring needed, same pans used in cooking may be used in serving
- optimize floor space
- more food cooked within the floor space required by a range



Additional advantages when compared to pressureless steamers:

- uses less energy
- uses less water

Installation tips:

- recommend a water treatment system be installed to enhance preventive maintenance
- stay within the distance for drains required by the manufacturer
- steamers require a cold water supply which fills the steam generator and supplies the cold water condenser
- open air gap floor drains are also required within a specific distance from the steamer



High pressure steamers are offered in counter top, stand, or cabinet base mounted models. There are several model sizes manufactured. The largest model available may accommodate three 12" x 20" x 2" pans in a single cooking compartment.

Steamers are available in self-contained electric, gas, or direct steam models. They are also available mounted on electric, gas, or steam coil generator (boiler) in a cabinet base.

The counter top models require no water or drain connection. Water is filled and drained manually. Generator (boiler) based models require a hot and cold water supply and open air gap floor drain connection. The operation is automatic.

The self-contained countertop models require a heat-up time on each cooking cycle. The steam generator (boiler) based units require an initial heat-up time for the steam generator then steam is readily available for each cooking cycle.

The cooking compartment door is an inside self-sealing type and cannot be opened during a cooking cycle.

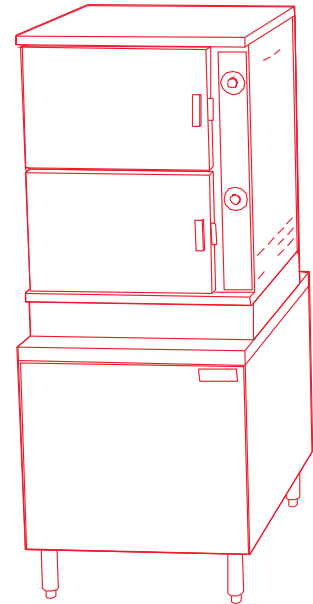

Standard features of high pressure steamers:

- timer and buzzer
- indicator light
- automatic controls and exhaust
- stainless steel exterior
- inside self-sealing door with gasket
- generator base models - automatic water-fill and blow down

Options and accessories at extra cost:

- increased KW on electric generator based models
- increased BTU on gas generator based models
- special electrical requirements
- stainless steel stand
- stainless steel adjustable feet
- ball float trap - direct steam models
- pressure-reducing valve - direct steam models



Combination Oven/Steamer

The combination oven/steamer offers a single cooking chamber with the ability to cook in three cooking modes which include hot air mode (convection oven), a steam mode (convection pressureless steamer), and a combination of both modes (circulating hot air with superheated steam). The combination oven/steamer may cook in all three modes independently or in sequence moving from one mode to another depending on the menu item, i.e., starting the cooking cycle of a roast in the steam mode to sear the outside and accelerate the cooking process, move to the combination mode to reduce shrinkage and the cooking time, and finish in a high temperature convection hot air mode to enhance the outside color.

Combination oven/steamers are available in gas or electric models.

They are available in two generic sizes which are half size and full size. Half size models accommodate 12" x 20" x 2" pans or 13" by 18" sheet pans. Full size models accommodate 12" x 20" x 2" pans and 18" x 26" sheet pans. Both sizes are available in several capacity sized models. Some manufacturers describe sizes in levels or pan racking positions, such as 10 levels. Models up to 10-11 pan capacity can be mounted on tables, stands, or even double stacked. Both half and full size models in the 20 pan capacity or level become floor models with roll-in carts.

Application:

Roast, steam, bake, poach, blanch, grill, defrost, cook-and-hold, and rethermalize.

Examples:

- vegetables
- meats
- poultry
- seafood
- muffins
- breads
- pizza
- prepared foods
- frozen entrees

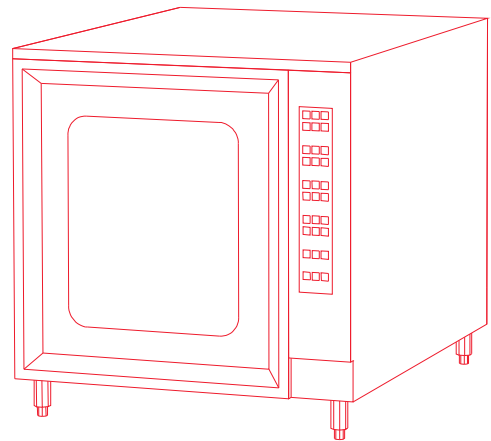

Standard Features:

- three cooking modes - convection hot air, convection steam, combination of convection hot air, and steam (variations to the steam mode are available with some manufacturers)
- micro-processed controls
- control panel includes selection of cooking modes, time and temperature, some manufacturers offer various other functions fan speed, KW input, vent control, water spritzing, cool down, cook, and hold
- programmable memory may be considered an option
- built-in diagnosis
- fan filter system
- delimiting ability
- safety controls for water level
- high limit thermostat
- drip trough for cooking chamber
- electronic ignition for gas models
- cold water condensing system
- spray hose assembly may be considered an option

Table 5.9 Combination Oven/Steamer Information

Model/Type	Capacity/size/level
Counter top or stand	4-6 pan/level-half size
Mounted - electric	10-11 pan/level-half and full size
Mounted - gas	10-11 pan/level-half and full size
Roll-in/floor base - gas	20-23 pan/level half and full size
Roll-in/floor base - electric	20-23 pan/level half and full size

Options and accessories at extra cost:

- stainless steel support stands
- landing or loading tables
- roll-in carts
- pan slides for stands
- additional pan racks/wire shelves
- casters
- water treatment system
- special electrical requirements



Installation tips:

- open air gap drain should be located within the distance from the unit recommended by the manufacturer

Advantages:

- flexible
- cooking times are reduced
- meats are cooked with less shrinkage
- quality of cooked foods may be enhanced
- large cooking capacity



Convection Oven

The convection oven offers a cooking chamber with a fan to circulate hot air. This is called forced convection heat which is the origin of the convection oven name. Convection ovens are available in gas and electric models.

Convection ovens are offered in single, double stacked, and roll-in models. Each cooking chamber has 11 rack guides and is supplied with five racks.

These ovens are available in two depths. The standard depth model accommodates 18" x 26" sheet pans in a right to left loading position. The extra deep depth model accommodates 18" x 26" sheet pans in a right to left and/or front to back loading position.

The two doors on each cooking chamber are available in two basic configurations 60/40 or 50/50. The doors open and close either independently or simultaneously on a pulley system. Doors are offered with glass window panels or solid stainless steel.

Manufacturers offer various control packages. The control packages range from mechanical thermostats and dial timers to solid state controls that are digitally displayed to computer based controls that are programmable. Coding features are also offered in the control packages such as fan delay, cook and hold, and moisture injection.

Application:

Bake, roast, slow roast and hold, and rethermalize

Examples:

- bread products
- cookies
- cakes
- pies
- meats poultry
- seafood
- frozen entrees
- pizza
- potatoes
- grilled cheese sandwiches
- macaroni and cheese

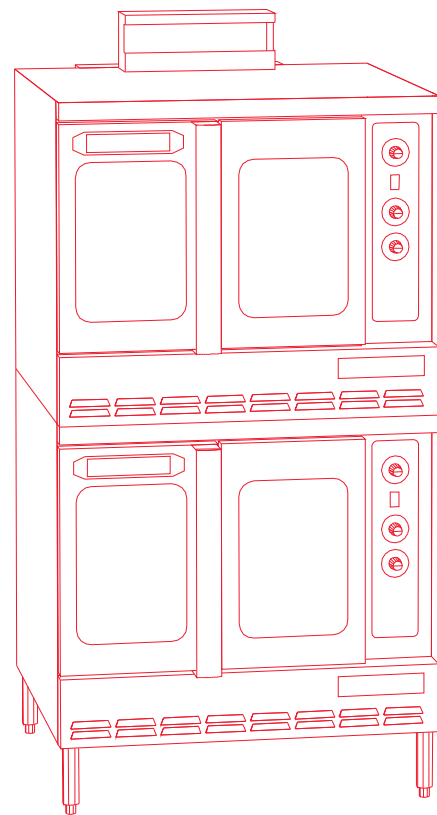

Standard features:

- stainless steel front, painted sides, top and legs
- double pane thermal glass windows in stainless steel door frames (doors may be solid stainless steel)
- porcelain interior liners in cooking chamber
- interior oven lights
- cool to touch door handles - design varies
- HP two speed fan motor (1/2 HP two speed and single speed also offered)
- 140° F to 500° F thermostat range (varies with control package)
- timer varies with control package
- stainless steel door gaskets
- eleven position rack guides per deck
- five plated racks supplied per deck
- rapid cool down function
- electronic ignition system (gas models)
- gas connection with manual shut-off valve and pressure regulator (gas models)

Table 5.10 Combination Oven Information

Model/Type	Capacity/size/level
Electric and Gas - Full size, single deck	Standard and Deep Depth 11- 18" x 26" sheet pans
Electric and Gas - Full size, double deck	Standard and Deep Depth 22 - 18" x 26" sheet pans
Gas and Electric Roll-In - Single Deck	Standard and Deep Depth 10 - 18" x 26" sheet pans
Gas and Electric Roll-In - Double Deck	Standard and Deep Depth 20 - 18" x 26" sheet pans



Options and accessories at extra cost:

- control options - cook and hold, fan delay, moisture injection, programmable functions
- solid state controls
- computer controls
- stainless steel exterior - top, sides, legs
- casters
- drip pans
- solid stainless steel doors (when glass windows are standard)
- stainless steel interior
- open stand with rack guides
- rear enclosure panel-painted or stainless steel
- base cabinet with finish options
- additional racks
- special electrical requirements
- flue diverters and adaptors (gas models)

Installation tips:

- measure doors and aisle space to ensure the oven will fit into kitchen
- gas ovens must be vented under a hood or through a flue stack; flue diverters and adaptors are available from the manufacturer
- measure the hood height to ensure oven will fit under the hood

Advantages:

Observed when compared to conventional oven cooking:

- more product cooked in less floor and hood space due to rack design
- energy savings are observed due to reduced cooking times, and lower cooking temperatures
- better heat distribution results in more even baked products



Fryer

There are three basic components to every fryer:

- the fry tank
- the burners heating elements or electromagnetic induction heating coils
- the controls

The fryer uses hot oil as the heat transfer.

Fry tanks:

There are two basic designs of fry tanks for gas fryers which are the bottom fired design and the tube fired design. Induction fryers also use the tube fry tank design.

The fry tank design for electric models has a slightly flat tank bottom with immersion type elements. A “cool zone” is necessary for trapping food particles, minimizing carbonization, prolonging oil life, and reducing flavor transfer.

Burners, heating elements, induction heating coils, and gas burners that are commonly used are atmospheric burners which may also be engineered as a power burner and infrared tile burners. Electric heating elements that are commonly used are the flat ribbon style heating elements and alloy stainless steel sheath heating elements.

Controls:

Controls are key to maintaining temperature. The closer the set point (cooking temperature) is maintained the better the cooking results. Select a fryer based on menu and operational requirements.

There are three basic types of controls:

- Millivolt controls. The self-generating millivolt system has a 10 second delay response to temperature. A temperature swing of 20° F may occur with this system.

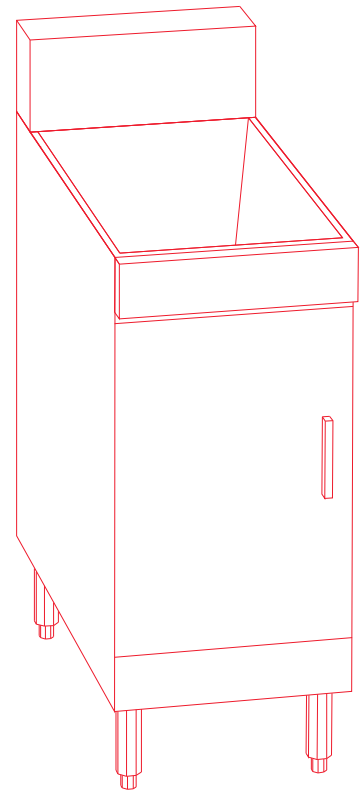

- Solid state controls. This electronic control has modulating thermostats and may react to +/-2° F.
- Computer controls. This control system has proportional integral derivative (PID) heat control and may react to +/-1° F. This control offers various programmable functions. Manufacturer and service diagnostics may also be offered with this system.

Fryers are categorized in size by the capacity of the frying compound and the pounds of frozen food which may be cooked in one hour. Fryers are available as independent/stand alone units or battered/banked as several units together.

Filtering removes carbonized particles that cause dark color and off flavor in fried foods. Filtering may be done manually or automatically with a filtering system.

Various types of filters are available like the roll-around (mobile or portable), the slide out drawer filter, or the built-in filter. Each manufacturer offers a partnering filter system with their fryer line.

Table 5.11 Fry Information

Model/Type	Fry compound capacity	¼" Fried potatoes per hour approximated
Gas	35-40 lbs	65 lbs
	45-50 lbs	100 lbs
	65-70 lbs	115 lbs
	70-85 lbs	115 lbs
Electric	30-35 lbs	62 lbs
	50 lbs	80 lbs
	78-82 lbs	105 lbs

Application:

Examples:

- french fried potatoes
- tater tots
- onion rings
- variety of fried vegetables
- chicken
- chicken nuggets
- fish sticks or nuggets



Standard features:

- stainless steel front top
- thermostat control-millivolt, solid state, computer 200° F - 400° F
- 1" (1¼") full port drain valve
- basket hanger
- rear gas line connections
- twin baskets
- 6" adjustable legs
- high limit control

Options and accessories at extra cost:

- stainless steel fry tank cover
- selection of extra baskets and screens
- skimmer
- crumb scoop
- tank brush
- automatic basket lifts
- upgrade to stainless steel fry tank (if not standard)
- casters
- upgrade choice of controls
- flex hose and quick disconnect with restraining device
- stainless steel exterior-front, sides
- landing station
- warming lamp for landing station
- filter system

Installation tips:

- National Fire Protection Association requires fryers to be positioned at least 16" away from any open flame cooking equipment. NFPA # 96 9-1.2.2
- space over fryer has a code approved hood and fire suppression system
- follow start-up instructions for initial cleaning "boil out" of the fryers to eliminate dust, grease, and other contaminants

Advantages:

Observed when compared to deep fat frying on top of a range:

- ease of operation
- safer when frying at high temperatures in a contained piece of equipment
- capable of handling continuous batches
- quality of fried foods is enhanced



Two Burner Range

The range has two gas burners (gas fired models) or electric hot plates (electric models) in a cabinet stand. The range is used to supplement primary cooking equipment.

Application:

Supplemental heating surface

- boiling water
- melting butter

Standard features:

- stainless steel cabinet exterior - front, top, sides
- 6" stainless steel adjustable legs
- two removable cast iron burners with lift off heads (gas model)
- two hot plates (electric model)
- removable cast iron top grates (gas model)
- removable crumb tray under burners (gas model)
- rear gas connection and gas pressure regulator (gas model)

Options and accessories at extra cost:

- single or double pantry faucet
- stainless steel rear panel
- stainless steel rear flanged feet
- griddle hot top

Accessories for ranges:

- ovens - conventional and convection
- broilers

Installation tips:

- space over range has a code approved hood and fire suppressions system

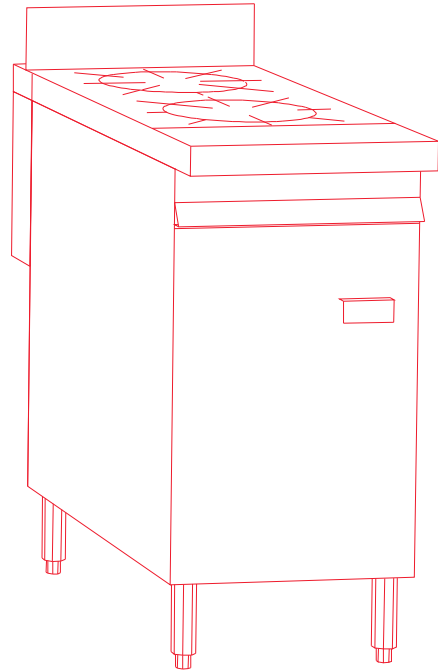

Table 5.12 Range Information

Model/Type	Size/Capacity
Gas	Two burners
Electric	Two hot plates

Food Processor

There are numerous manufacturers of food processors available. Most are compact in design to use less counter space. Use a commercial model not a home-style unit.

Application:

- texture modification
- food processors are used to speed up the production/preparation time of some recipe ingredients and or menu items
- food processors dice, slice, grate, shred, and julienne food
- continuous feed units process food quickly with uniform pieces
- labor saving

Standard Features:

- interchangeable cutting tools/plates, some are stainless steel
- some models have handles for carrying
- NSF - UL listed
- can process up to 400 - 1000 lbs. per hour

Options and accessories available at extra cost:

- variety of cutting tools/plates
- wall mounting racks to hold cutting tool/plates
- gun to put puree in a form
- attachments (slicing plate, pulping plate, grating plate, and others)

Advantages:

- quality of finished product - consistent uniform pieces
- labor saving
- less waste versus product cut by hand
- reduces injury-work related compensation, lost time
- versatility

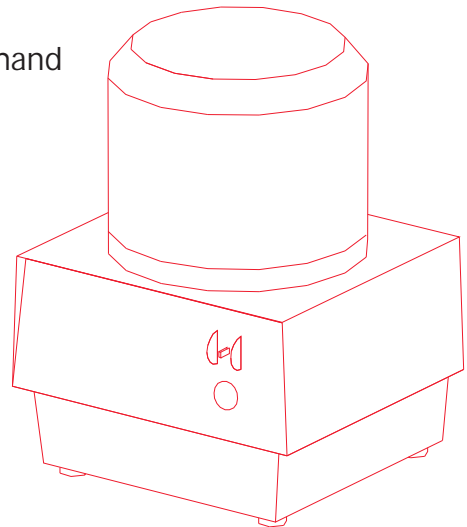

The food processor is a versatile piece of equipment that may be moved between the cold and hot food production areas to meet special dietary needs for textual modification.

Texture modifications using the processor may include:

- Regular: Texture of the food served regularly to children who participate in the lunch or breakfast programs.
- Chopped: Use a food chopper, a food processor, or even a knife to cut the food into bite sized pieces.
- Ground: A food processor or blender is used to grind the food until it is soft and small enough to swallow with little or no chewing.
- Pureed: Pureed food is smooth in texture and the consistency of mashed potatoes. A food processor or blender is used to puree foods. Add a small amount of liquid to avoid dryness.



Ventilation

Cooking equipment in the hot food production area can be considered a generator of contaminated air. The quantity of this air is developed by each piece of equipment based on temperature and size of physical cooking area. Properly designed ventilation systems relate to a safe and efficient kitchen.

Proper kitchen ventilation is a complex application of the HVAC system:

- air conditioning
- fire safety
- ventilation
- building pressurization
- refrigeration
- air distribution
- foodservice equipment

Reasons for a ventilation system include:

- remove heat, grease, odor, smoke, steam, and flue gas by-products from the kitchen.
- provide a comfortable and productive kitchen environment.
- enhance safety of personnel.
- provide fire protection in the kitchen.

Center piece of the ventilation system is the exhaust hood. Hood styles include:

- wall mounted canopy
- single island canopy
- double island canopy
- back shelf (counter height equipment)
- eyebrow (direct mounting to ovens and some dishwashers)

Hood will remove:

- steam
- heat
- grease
- smoke
- odor
- flue gas by-product



Check local code requirements for type of hood required. When designing a new foodservice system ventilation requirements should be carefully reviewed due to the cost.

Factors to consider in a kitchen ventilation system:

- hood size
- filter size
- filter placement
- introduction of makeup air

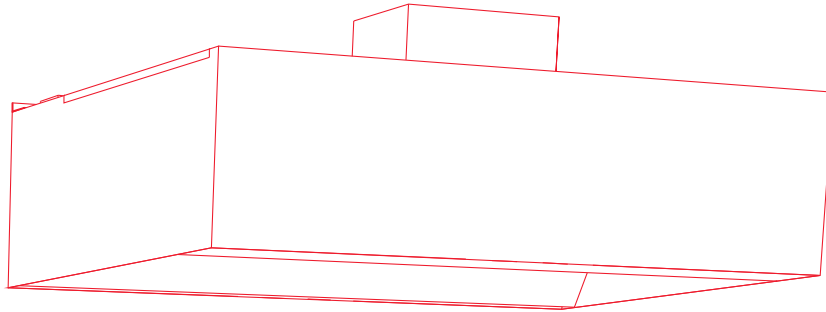

Holding Cabinet - Heated and Unheated

Many CNPs use the hot holding cabinet as an interface between production and service. This provides a safe temperature controlled storage of cooked and ready-to-eat food items to meet service demands. All hot foods should be held above 140° F to assure they will not be held in the temperature danger zone. Selection of the holding cabinet with humidity control, for example, is important to maintain food quality.

Heated holding cabinets are also known as warming cabinets or heater/proofer cabinets. The unit is an enclosed cabinet designed to hold baking pans or steamtable pans. Their function is to hold prepared food hot for service at a set temperature. Unheated cabinets are used for holding and transporting large quantities of prepared foods not requiring to be held at a set temperature. Holding cabinets come in a variety of styles for both heated and unheated models; mobile or stationary; reach-in, pass-thru, roll-in, or roll-thru. They are made with glass or aluminum doors.

Application for heated cabinets include:

- meat
- poultry
- fish
- pizza
- vegetables
- breads, muffins, biscuits, rolls
- proofing bakery dough

Application for unheated cabinets include:

- breads, muffins, biscuits, rolls
- prepared desserts
- catering set-up

Standard features for heated and unheated cabinets:

- all welded construction
- full perimeter bumper
- reinforced doors for added support
- heavy duty casters with brakes for mobile units
- front stainless steel drip trough
- fully insulated for heated units
- 8 ft. heavy duty cord and plug
- door mounted thermometer (heated)



Options and accessories available at extra cost:

- corner bumpers
- stainless steel push handle
- mechanical set timers (heated)
- universal slides
- controlled humidity

Advantages of cabinets:

- supports efficient production
- mobile and stationary options
- easy to clean and service

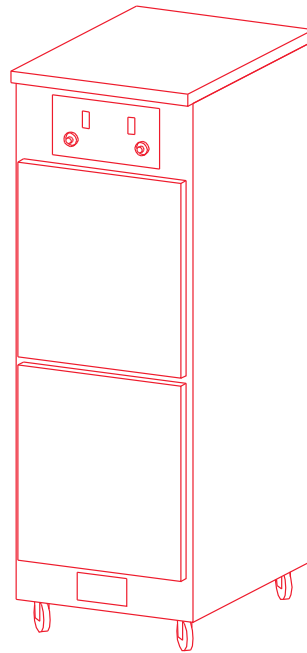

WAREWASHING

The functional area of dish and tray washing is important within the foodservice system. It is here that soiled dishes, glasses, flatware, and trays are visibly cleaned and sanitized. Within the warewashing area there are a number of tasks that must be completed like, scraping, racking, prewash, wash, rinse, sanitize.

Dishmachines

The dishmachine is a major investment and commitment. There are a number of considerations when selecting dishmachine features:

- proper ventilation - otherwise there is excessive humidity and possibly poor/unsafe working conditions
- adequate lighting - allows staff to see broken glass and excess water accumulation
- proper utilities available - inadequate power can damage machine or there can be non-performance
- drain size and location
- walls, floors and ceiling should resist moisture, absorb sound, easy to clean
- booster heater
- capacity based on number of meals
- cleanability

Four wash functions:

- Scrapping and pre-wash: 100° - 120° F
remove soil
- Wash: solution of hot water 140° - 160° F and detergent
soften soil, melt grease
- Rinse: 160° - 180° F
- Final rinse/sanitize: 180° - 195° F
sanitizing

Note: a booster heater is needed to maintain water at 180° F.

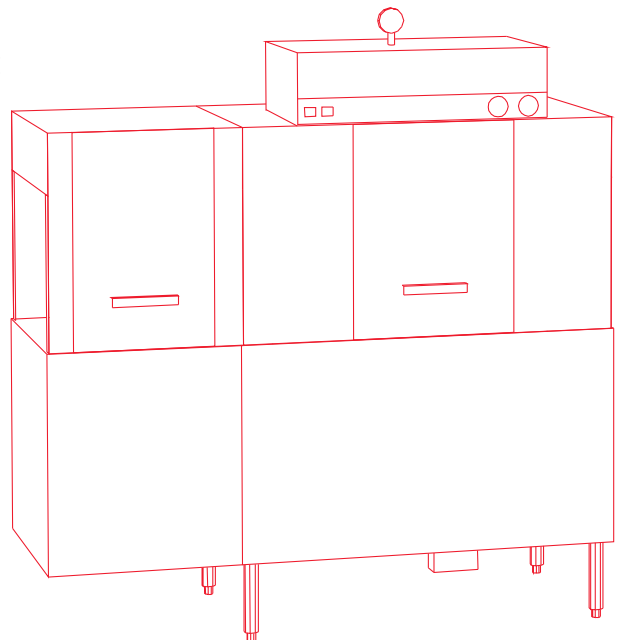

Elements of the dishmachine:

- time - time and cost efficiency
- temperature - thermostat to help regulate, booster (if necessary)
- water pressure - to take care of protein soil
- detergent - based on hard water, light/heavy soil
- rinse addition - water conditions

Standard features:

- automatic tank fill
- detergent/chemical connection provisions
- door activated drain
- door safety switches
- interchangeable spray arms
- leakproof doors

Table 5.13 Typical Dishwasher Capacities

Type of Dishmachine	Dishes / Hour	Racks / Hour
Single-Tank Door	1,550	53-62
Two-Tank Conveyor	5,850	205-234
Three-Tank Conveyor	6,650	234-272
Flight Type	12,000	0 - 0

Low temperature dishmachines are also available. It should be noted that silver, aluminum, and pewter are attacked by sodium hypochlorite or liquid bleach. Look for a machine that is designed for a liquid bleach solution not exceeding 50 ppm. Pumps will dispense detergent, sanitizer, and drying agent in liquid form. In a low temperature dishmachine the temperature requirement is 140° F.

Standard features:

- automatic tank fill
- convenient controls
- door safety switch
- leakproof door
- low water tank heat protection
- stainless steel heavy gauge construction including base and legs



If your CNP does not use a dishmachine, set up a three-compartment sink away from food production areas. Include an area for scraping into a disposer or garbage container. A drain area is required for clean items. The three compartments include:

- wash - detergent solution at least 110° F
- rinse - clear water at 120° F
- sanitize - submerge items in hot water at 170° F for 30 seconds (some require 180° F) or place in chemical sanitizer at least 75° F.
- air dry

In addition to the dishmachine, there are several other pieces of equipment that are considered integral components of the washing system. They include:

- potwashing machines
- trash compactors
- garbage disposers
- pulpers

Pot, Pan, and Utensil Washers

Pot washers operate in much the same way as door-type machines. There are, however, some differences that include:

- larger motor to pump water
- more horsepower to create high-velocity water stream to strip off encrusted food
- internal size

The specifications of a pot washer is determined on the basis of the volume of pots and pans to be washed. Some CNPs elect to use a standard three compartment sink for washing pots, pans, and utensils.

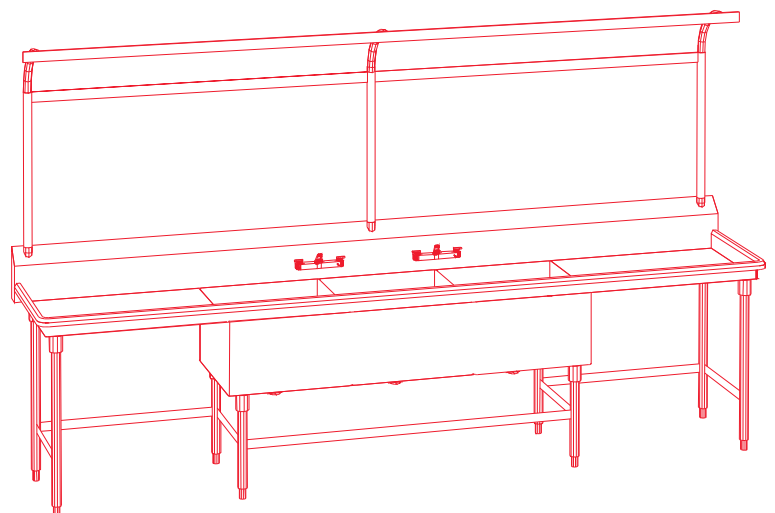

Waste Handling

Other equipment needed is for waste handling:

- garbage disposers
- pulpers and other waste removal equipment
- trash compactors

Waste removal means liquid portions of the garbage is flushed into sewer system. This reduces weight and volume of the garbage. The CNP wants to reduce odors and vermin associated with garbage. Waste handling equipment allows for waste to be transported through a soil pipe (eliminates carrying heavy can to larger container).

Garbage Disposers

The primary function of the garbage disposer is to grind food waste and mix it with water. This mixture is then piped from the operation to the sewer. Commercial garbage disposers are usually specified by horsepower. The typical range is between $\frac{1}{2}$ and 5 horsepower.

Pulper and Extractor Systems

Some municipalities have ordinance against the use of commercial disposers because of the heavy load on the sewer system. Trash pulpers and compactors can significantly reduce garbage volume. Check local regulations before planning the purchase of a pulper and extractor system.

With a pulper, water and waste are mixed together; ground into small particles; piped to extractor; solids are separated from water; water returned to pulper and mixed with fresh water; water reused in grinding process; solids conveyed to conventional trash container. The final product looks like sawdust or ground paper.

A pulper and extractor system costs more than conventional disposers. However, the high initial cost is offset by:

- reduction in waste handling
- reduced water consumption
- labor simplification



Specifications:

- operate under dish table
- operate with extractor connected to a remote location (slurry piped from pulper to extractor)
- connect directly to the waste trough on a soiled dish table

Standard features:

- flatware saver
- common fill and drain connection
- flushing valve to pump motor seal
- flexible draw latches in hood assembly
- remote mounted control box with overload indicator lights circuit breaker
- start/stop switch
- stainless steel tubular bullet foot legs
- water level control

Small pulper

handle up to 475 pounds per hour

Larger, self-contained system

handle up to 700-900 pounds per hour

Trash Compactors

Mechanical device designed to compress waste materials so the volume is greatly reduced. Waste is easily transported out of food production area. Trash compactors have many obvious advantages. For large CNPs, the compactor may be installed at the back door of the kitchen. The garbage can be removed by trucks with a specially designed lift. Kitchens with a large accumulation of glass, boxes, and trash find the compactor to be an advantage.

Suggested equipment for conventional kitchens include:

- dishmachine
- disposer
- booster heater
- hand sink
- soiled dish table
- clean dish table
- pre-rinse sink with spray
- racking shelf
- tray dispensers
- dish dispensers
- utility carts



References for Chapter 5

- Battistone, S. (1991). *Spec-rite-kitchen equipment*. Cincinnati, OH: The Food Service Information Library.
- Hogue, M. A. & Post, L. S. (1998). *All-star receiving for child nutrition*, NFSMI-ET 17-98. University, MS: National Food Service Management Institute.
- National Food Service Management Institute. (1997). *The new design handbook for school food service*, NFSMI-E11-95. University, MS: Author.
- Nettles, M. F. & Carr, D. H. (1996). *Guidelines for equipment to prepare healthy meals*, NFSMI-R24-96. University, MS: National Food Service Management Institute.
- North American Association of Food Equipment Manufacturers. (1994). *An introduction to the foodservice industry*. 1st ed. Chicago, IL: Author.
- North American Association of Food Equipment Manufacturers. (1994). *Handbook of steam equipment* 94.11. Chicago, IL: Author.
- Scriven, C. & Stevens, J. (1990). *Food equipment facts a handbook for the food service industry*. Valley Falls, NY: Conceptual Design.
- United States Public Health Service. (1997). *Food code* (DHHS Publication No. PB97-141204). Washington, DC: U. S. Government Printing Office.

